

OUTDOOR EQUIPMENT & TOOLS

Your Partner in Power and Precision

From our state-of-the-art farm equipment to our innovative attachments, Rex Equipment is built with one goal in mind: to help you work smarter, not harder. Our equipment isn't just about getting the job done, it's about doing it better. Engineered with precision and tested in the toughest conditions, Rex products deliver reliability you can count on year after year.

REX





Outdoor Equipment & Tools

Table of Contents



A

ATV Finishing Mower	355
ATV Trailer, Electric 3 Stage Hydraulic Tipper	357

B

Box Scraper	361
-------------------	-----

E

Emergency Fire Pump Kit	366
-------------------------------	-----

F

Field & Brush Mower.....	355
Flail Mower	356
Flail Mower	360

G

Garlic Planter	368
Garlic Roots Cutter	369
Garlic Splitter and Sorter.....	370

H

Heavy Duty Rear Grader Blade	359
Heavy Duty Slasher.....	360
High Performance Pressure Washer.....	374
Hydraulic Post Digger	367

K

Kerosene Air Heaters	372
----------------------------	-----

O

Open Frame Gas Generator.....	362
-------------------------------	-----

P

Portable Electric Salamander Heaters	373
Portable Semi-Trash Pump	364
Portable Water Pump	365
Propane Forced-Air Heater	371

Q

Quick Hitch.....	362
------------------	-----

R

Rear Grader Blade.....	359
Rotary Tiller.....	361

S

Sickle Mower	367
Silent GAS Inverter Generator	363
Single Axle Trailer.....	356
Spreader.....	358
Stump Grinder	368

T

Trailer Tandem Axle	357
---------------------------	-----

U

Utility Trailer	358
-----------------------	-----





RMD44

Field & Brush Mower

This tow-behind, gas driven ATV field and brush mower provides several benefits, including its ability to handle tough terrain and cut through thick vegetation.

It is perfect for use in agricultural and forestry settings, where it can be used to clear brush, small trees, and tall grass. This mower is easy to tow behind an ATV and is adjustable to accommodate different types of terrain. It is powered by a gas engine, making it efficient and convenient.



- 1 Chains protect against flying discharge
- 2 674cc displacement
- 3 Gasoline engine with electric start
- 4 Suitable for tall grass (up to 7"), weeds and brush up to 9" tall and saplings up to 3" thick
- 5 Simple one-man deck height adjustment
- 6 16" robust lugged pneumatic wheels (with tube)
- 7 Floating deck design moves with the terrain's contours, eliminating scalping for an even cut every time.
- 8 5 offset tongue positions for all projects
- 9 13" flat free front wheel

FEATURES

- Ignition and on/off switch located by engine mount
- Throttle linkage mounted beside engine
- Accessible fuel shutoff valve

DETAILS

# OF BLADES	2
ENGINE MODEL	20HP Kohler CV680
CUTTING WIDTH	44"
CUTTING HEIGHT	3.9" - 9.4"
FRONT WHEELS	13 x 5.00-6
BACK WHEELS	16 x 6.5-8
PACKAGING DIMENSIONS	87"L x 49"W x 32"H
WEIGHT	750 lb
OIL CAPACITY	1.9 L
GAS CAPACITY	15 L
HR/RPM	20 / 3600

REPLACEMENT ITEMS

RMD44-1	Blade Replacement
RMD44-2	Belt Replacement

DMH120

ATV Finishing Mower

This tow-behind, gas-driven finishing mower provides several benefits, including its ability to provide a smooth, even cut on lawns and fields. It is ideal for use in residential and commercial settings, where it can be used to maintain a well-manicured appearance.

This mower is easy to tow behind a tractor or ATV and is adjustable to accommodate different types of terrain. It is powered by a gas engine, making it efficient and convenient.



- 1 Heavy Duty reinforced mower frame
- 2 452 cc displacement
- 3 Electric start
- 4 Rear damper system to prevent piles & clumps
- 5 Double mulching blades
- 6 Heavy Duty cast iron and greasable blade spindles & hubs
- 7 Turf-friendly 3"x 8" solid rubber wheels with a greasable hub
- 8 Pressed steel wheel forks

DETAILS

# OF BLADES	3 (double)
ENGINE MODEL	16HP Loncin LCIP92F-1
FUEL CAPACITY	6.5 L
OIL CAPACITY	1.2 L
HR/RPM	16/3600
CUTTING WIDTH	48"
PACKAGING DIMENSIONS	50"L x 47"W x 24"H
WEIGHT	462 lb

REPLACEMENT ITEMS

DMH120-1	Replacement Belt
DMH120-2	Replacement Blade





Outdoor Equipment & Tools

Tow Behind



Outdoor Equipment & Tools

ATV120

Flail Mower

Designed with the acreage owner in mind, this flail mower easily attaches to your quad or lawn tractor to cut, mulch, and groom your entire property in a fraction of the time you're currently spending.

This versatile unit utilizes commercial grade hammer blades to stand up against the toughest grass, brush & overgrown vegetation. Its rear discharge design reduces the risk of injury from flying debris.

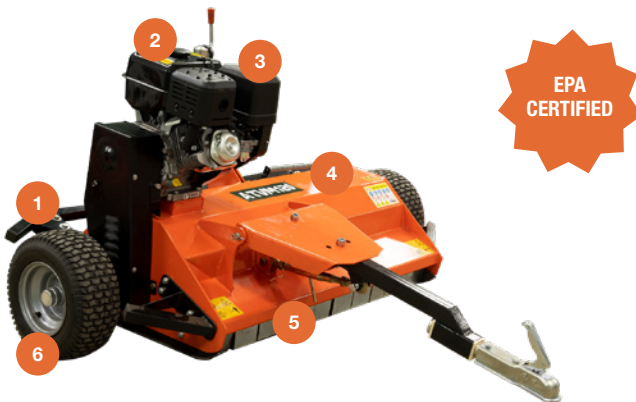

- 1 Full-width rear discharge for cutting wide swaths and evenly spreading grass clippings
- 2 420CC displacement
- 3 4 Stroke, single cylinder gasoline engine with electric start & forced air cooling
- 4 Seriously reduces mowing time on large lawns (2100-2500m²/hour) and easily cuts grass up to 8" tall
- 5 Adjustable mowing deck height from 0" - 6" to tackle all areas of your property
- 6 Height-adjustable rubber balloons with spring-locked crank. Dimensions: 16.5"x6.5"

KIT INCLUDES

- Document Holder
- Front Mudguard
- Oil Level Monitor

DETAILS

# OF BLADES	28
BLADE TYPE	Hammer
ENGINE MODEL	Loncin G420FD
FUEL CAPACITY	6.5 L
OIL CAPACITY	1.1L
HP/RPM	15/3600
CUTTING WIDTH	48"
PACKAGING DIMENSIONS	84"L x 34"W x 32"H
WEIGHT	680 lb

REPLACEMENT ITEMS

ATV120-1	Replacement Hammer Blades for ATV120
----------	--------------------------------------

LT-02

Single Axle Trailer

This tow-behind ATV single axle trailer provides several benefits, including its ability to carry heavy loads and provide greater stability on rough terrain. Used on the most demanding terrain, it can be used to transport equipment, supplies, and materials.

The trailer is equipped with a single axle and larger wheels, making it more stable and able to handle heavier loads. It can be towed behind an ATV or small tractor, making it efficient and convenient.



- 1 Commercial-grade construction and heavy-duty materials
- 2 Removable end panels to accommodate longer payloads
- 3 Aggressive off-road utility pneumatic tires
- 4 Pivoting hitch ball coupler for a smooth ride over the most uneven of terrain
- 5 Heavy duty steel frame guards

DETAILS

CAPACITY	1100lbs (500kg)
DUMP ANGLE	35°
HITCH BALL COUPLER	2"
TIRES	22" x 11-8
PACKAGING DIMENSIONS	64"L x 41"W x 27"H
WEIGHT	274 lb





LT-16

ATV Trailer, Electric 3 Stage Hydraulic Tipper

The tow-behind ATV tandem axle trailer with tilt feature provides several benefits, including its ability to easily load and unload heavy equipment or materials.

It is generally used in an outdoor setting, where it can be purposed to transport equipment, supplies, and materials. This trailer is equipped with two axles and larger wheels for stability, and has a tilt feature that allows for easy loading and unloading. It can be towed behind an ATV or small tractor, making it efficient and convenient.

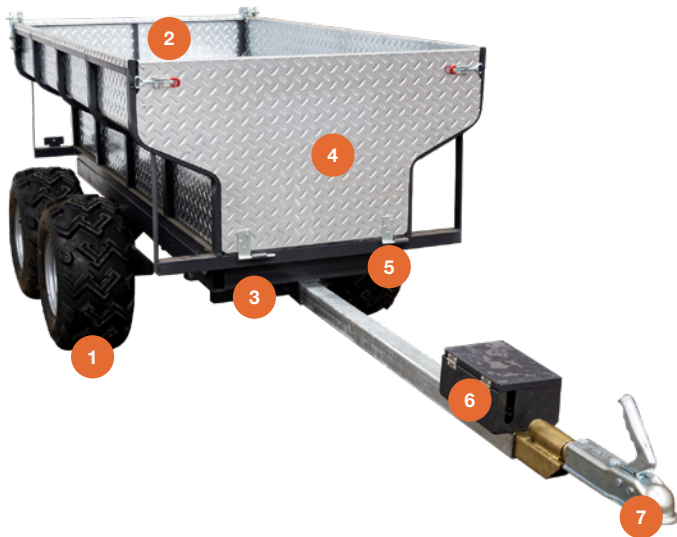

- 1 Robust all-terrain pneumatic tires
- 2 Headboard and tailgate can be removed for longer loads
- 3 Sturdy floor tread plate
- 4 Powerful three-stage hydraulic ram for complete payload evacuation
- 5 Bogie Axle Type
- 6 Practical tow bar mounted storage box for the actuator and small tools
- 7 Pivoting hitch ball coupler for a smooth ride over the most uneven of terrain

DETAILS

CAPACITY	3131 lb (1,420 kg)
TIPPER	Electric Hydraulic 12V
HITCH BALL COUPLER	2"
TIRES	22" x 11-10
BOX DIMENSIONS	78.74" L x 42.13" W x 22.83" H
PACKAGING DIMENSIONS	84" L x 45" W x 23" H
WEIGHT	640 lb

LT-01B

Trailer Tandem Axle

The tow-behind ATV tandem axle trailer provides several benefits, including its versatility, maneuverability, and ease of use. Used to transport equipment, supplies, and materials, this trailer is lightweight and easy to maneuver, making it perfect for use on rough terrain.



- 1 Aggressive off-road pneumatic utility tires
- 2 Galvanized dump box is mounted to it's own powder coated reinforcement structure for added rigidity
- 3 Heavy duty steel frame guards
- 4 Removable end panels to accommodate longer payloads
- 5 58 cm box-ground clearance
27.5 cm frame-ground clearance
- 6 Chassis constructed with 4mm thick square steel tubing with galvanized coating to protect against nature's elements
- 7 Pivoting hitch ball coupler for a smooth ride over the most uneven of terrain

TANDEM AXLE

- The complete chassis connects to a heavy-duty tandem axle system featuring 4-bolt hub bearings where the utility tires are mounted
- The tandem axle utilizes one pivoting pin that comes standard with a greaseable zerk fitting

DETAILS

CAPACITY	2200lbs (1,000kg)
DUMP ANGLE	35°
HITCH BALL COUPLER	2"
TIRES	22" X 11-10
BOX DIMENSIONS	78.74"Lx47.24"Wx22.83"H
PACKAGING DIMENSIONS	84"L x 45"W x 23"H
WEIGHT	640lbs





Outdoor Equipment & Tools

Tow Behind



Outdoor Equipment & Tools

UT1100

Utility Trailer

This utility trailer is a versatile, rugged solution designed for all your hauling needs. Built with a powder-coated 11-gauge steel frame and rust-resistant materials, this trailer is engineered for long-lasting durability and a reliable performance. With a capacity of 1,100 lbs, it offers ample strength for transporting firewood, yard projects, hunting gear, ice fishing supplies, and more.



- 1 High impact polyethylene tray
- 2 Dumpable design: easily offload materials with less lifting effort with easy, quick release latch
- 3 Removable steel mesh side fence for secure load containment (assembly required)
- 4 Rust-resistant construction
- 5 Pin style hitch
- 6 2" hitch ball coupler ensures reliable towing connection
- 7 High ground clearance enhances maneuverability across diverse terrains
- 8 Steel wheel-bearings for easy maintenance and prolonged service life
- 9 Off-road pneumatic "tubed" tires facilitate easy maneuverability over various surfaces

DETAILS

CAPACITY	1100 lb (500 kg)
TIRES	18" x 8.50-8
HITCH COUPLER CLEARANCE	12"
TRAY-TO-GROUND CLEARANCE	16.5"
BOX DIMENSIONS	52" L x 25.5" W x 9" H
PACKAGING DIMENSIONS	48" L x 38" W x 14" H
WEIGHT	132 lb

SP003

Spreader

The tow-behind ATV spreader provides several benefits, including its ability to evenly distribute fertilizer, seeds, and other materials on large areas.

Used for farming, gardening, and landscaping, it can save you time and effort. This spreader is easy to attach to an ATV and can be operated by a single person.

It is adjustable to accommodate different types of materials, and is efficient and convenient.



- 1 Calibration control
- 2 Automatic flowing with spread pattern control
- 3 Screen and rain cover
- 4 Polyethylene hopper
- 5 Heavy-duty aluminum gears
- 6 Sturdy pneumatic tires

DETAILS

CAPACITY	60 L (56 kg/125 lb)
SPREADER REACH	10' x 12'
COVERAGE	25,000 sq ft
TIRE DIMENSIONS	4.10/3.50-6, 12" diameter
PACKAGING DIMENSIONS	31" L x 22" W x 18" H
WEIGHT	45 lb





RGB5

Rear Grader Blade

The ATV heavy duty rear grader blade provides several benefits, including its versatility, ease of use, and ability to handle a variety of grading tasks.

It can be attached to tractors and used to level roads, clear snow, and maintain driveways and parking areas. The blade is adjustable and can be angled to suit specific grading needs.

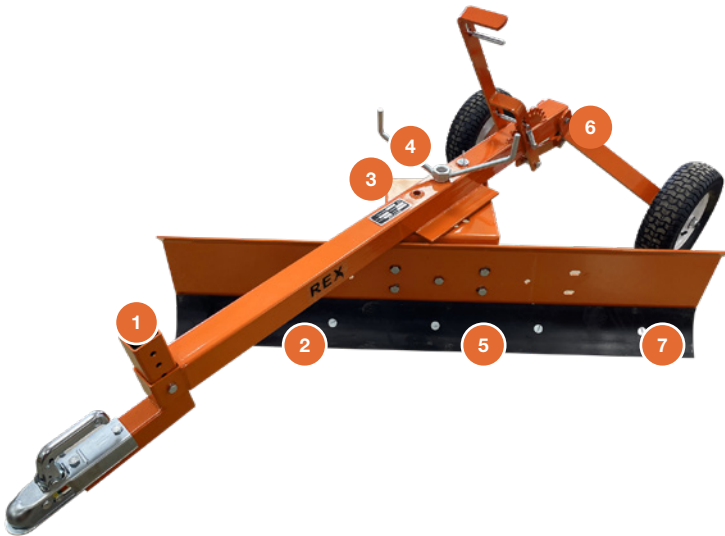

- 1 Adjustable hitch height
- 2 Standard grader blade
- 3 Good ground clearance on blade chassis and axle
- 4 360° off-settable cutting blade
- 5 Adjustable blade angle & height
- 6 Heavy-duty steel frame
- 7 Full blade tip design to prevent damage when striking objects

DETAILS

BLADE LENGTH	5'
HITCH COUPLER	2"
TIRE DIMENSIONS	16" x 6.50-8
PACKAGING DIMENSIONS	96" L x 24" W x 4" H
WEIGHT	247 lb

REPLACEMENT ITEMS

CUTEDGE-5	Replacement 5" cutting edge
-----------	-----------------------------

GBH5/GBH6

Heavy Duty Rear Grader Blade

The three-point hitch rear grader blade provides several benefits, including its versatility, ease of use, and ability to handle a variety of grading tasks.

It can be attached to tractors and used to level roads, clear snow, and maintain driveways and parking areas. The blade is adjustable and can be angled to suit specific grading needs.



- 1 Standard grader blade
- 2 360 degree off-settable cutting blade

DETAILS: MODEL GBH5

BLADE LENGTH	5'
REQUIRED HP	20-40 HP
PACKAGING DIMENSIONS	60" L x 50" W x 44" H
WEIGHT	200 lb

DETAILS: MODEL GBH6

BLADE LENGTH	6'
REQUIRED HP	30-55 HP
PACKAGING DIMENSIONS	72" L x 50" W x 44" H
WEIGHT	230 lb

REPLACEMENT ITEMS

CUTEDGE-5	Replacement 5' cutting edge
CUTEDGE-6	Replacement 6' cutting edge





Outdoor Equipment & Tools

3 Point Hitch



Outdoor Equipment & Tools

AGL125

Flail Mower

This three-point hitch, PTO-driven flail mower provides several benefits, including its ability to cut through thick vegetation, mulch materials into small pieces, and provide even distribution.

It is ideal for use in farming, gardening, and landscaping, where it can save time and effort. The mower is easy to attach to a tractor and can be operated by a single person. It is adjustable to accommodate different types of terrain and is equipped with durable blades for efficient operation.



- 1 When hooked to the front end float loader hydraulic function of the carrier unit, this flail mower will follow the natural contour of your terrain.
- 2 Rotor Tube made from heavy-duty steel tubing for long life
- 3 Reverse rotor rotation: the rotor spins opposite the wheels when traveling forward, allowing the blades to shear as the brush folded forward. The debris is then thrown up and over the rotor.
- 4 Precision blade overlap: the blades are staggered precisely with no gap, achieving an even cutting result

KIT INCLUDES

- 6SPL-1" PTO Shaft
- 40 Standard Y Blades
- 3 Belts

DETAILS

REQUIRED HP	20-40HP
REACH ANGLE	90° up, 55° down
ROTOR TUBE DIA.	4-1/2"
PTO	540RPM
CUTTING WIDTH	47"
PACKAGING DIMENSIONS	59"L x 30"W x 25"H
WEIGHT	600 lb

REPLACEMENT ITEMS

AGL125-1	Replacement V-belt
AGL125-2	Replacement Y blade

SL170

Heavy Duty Slasher

Three-point hitch, PTO-driven rough-cut mowers provide several benefits, including their ability to handle tough terrain and cut through thick vegetation.

They are ideal for use in agricultural and forestry settings, where they can be used to clear brush, small trees, and tall grass. These mowers are adjustable and can be used to mow both large and small areas. They are powered by the tractor's PTO, making them efficient and cost-effective.

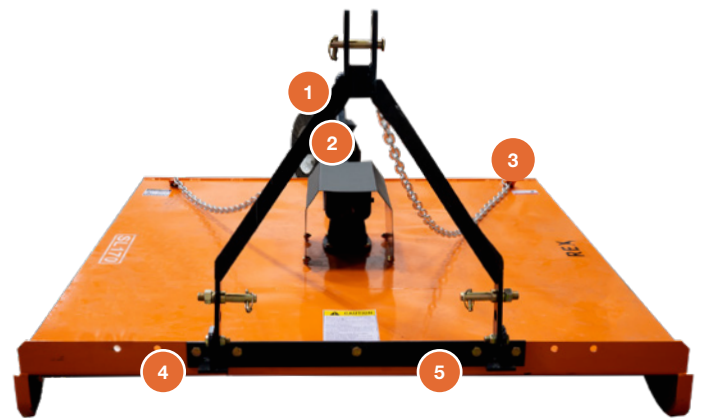

- 1 90° right angle gear box for simplified operation
- 2 Durable solid rubber rear tail wheel for durability
- 3 Stump Jumper hub for use in the worst cutting conditions
- 4 Cuts grass, weeds, and brush up to 3 inches in diameter
- 5 Free swinging blades

KIT INCLUDES

- PTO Shaft

DETAILS

REQUIRED HP	30-50HP
PTO SPEED	540RPM
CUTTING WIDTH	67"
PACKAGING DIMENSIONS	78.5"L x 72"W x 16.75"H
WEIGHT	500 lb

REPLACEMENT ITEMS

SL170-1	Replacement Blade
---------	-------------------





BSC5/BSC6

Box Scraper

Three-point hitch box scrapers provide several benefits, including their ability to level, grade, and smooth out large areas of land. They are a versatile choice for use in farming, landscaping, and construction, where they can save time and effort.

These scrapers are easy to attach to a tractor and can be operated by a single person. They are adjustable to accommodate different types of terrain and are equipped with durable blades for efficient operation.

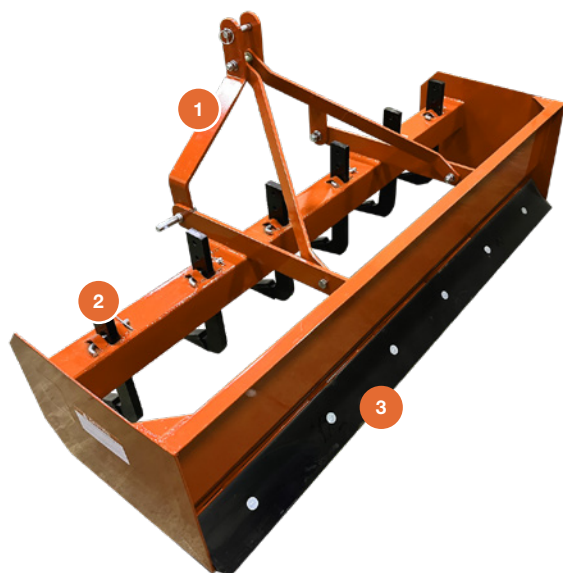

- 1 Heavy Duty steel frame construction and sturdy three-point hitch mount
- 2 Height adjustable and removable tines
- 3 Standard Grader Blade

DETAILS: MODEL BSC5

SIZE	5'
REQUIRED HP	20-35 HP
PACKAGING DIMENSIONS	60"L x 28"W x 36"H
WEIGHT	388lbs

DETAILS: MODEL BSC6

SIZE	6'
REQUIRED HP	25-45 HP
PACKAGING DIMENSIONS	72"L x 28"W x 36"H
WEIGHT	441lbs

REPLACEMENT ITEMS

BSC-1	Replacement ripper shank with tooth
CUTEDGE-5	Replacement 5' cutting edge
CUTEDGE-6	Replacement 6' cutting edge

TL125

Rotary Tiller

This three-point hitch, PTO-driven rototiller provides several benefits, including efficiency, versatility, and ease of use. It is excellent for use in farming and gardening, where it can be used to prepare soil for planting and cultivation.

This tiller is adjustable and can be used to till both large and small plots of land. It is powered by the tractor's PTO, making it efficient and cost-effective.

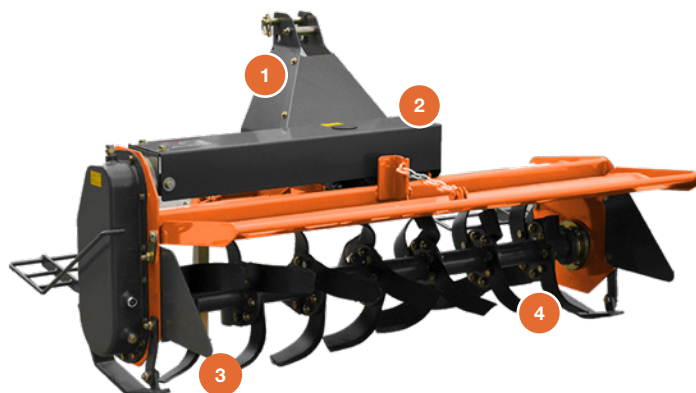

- 1 Maintenance-free oil bath transmission
- 2 Cat I 3-point 6-spline slip clutch driveline
- 3 Tilling couldn't be easier for the garden or new ground you need to break up for planting
- 4 Adjustable tilling depth

KIT INCLUDES

- PTO Shaft

DETAILS

REQUIRED HP	18-25 HP
WORKING WIDTH	49"
WORKING DEPTH	3-1/4" to 6"
PTO SPEED	540 RPM
PACKAGING DIMENSIONS	54"L x 28"W x 32"H
WEIGHT	518 lb

REPLACEMENT ITEMS

TL125-1	Replacement Chain
TL125-2	Replacement oil seal
TL125-3	Replacement left-bent blade
TL125-4	Replacement right-bent blade





Outdoor Equipment & Tools

3 Point Hitch • Generators



Outdoor Equipment & Tools

QHC1/QHC2

Quick Hitch

Three-point hitch quick hitches provide several benefits, including their ability to attach and detach implements from a tractor without the need for manual lifting or adjusting.

They are ideal for use in farming and landscaping, where they can save time and effort. These hitches are durable, versatile, and compatible with a wide range of implements. They are designed to improve efficiency and reduce operator fatigue.

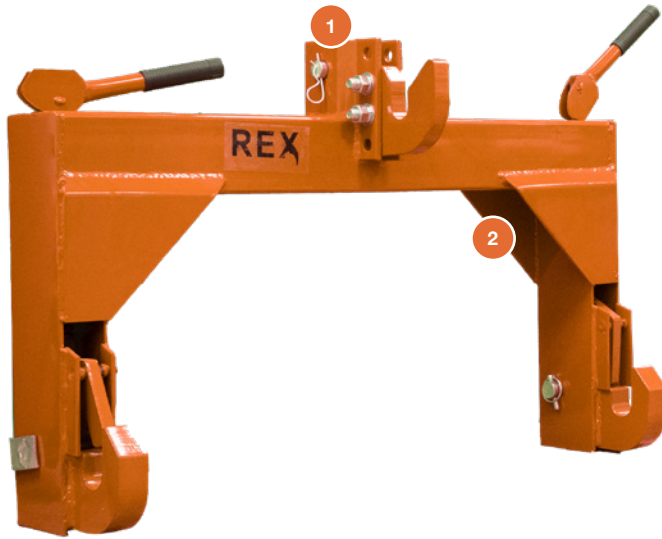

- 1 Adjustable top link
- 2 Heavy duty steel construction

DETAILS: MODEL QHC1

CATEGORY	1
MAXIMUM HP	50
BALL BRACKET WIDTH	27.5"
MOUNTING PIN DIAMETER	7/8"
PACKAGING DIMENSIONS	33"L x 25"W x 8"H
WEIGHT	58 lb

DETAILS: MODEL QHC2

CATEGORY	2
MAXIMUM HP	50
BALL BRACKET WIDTH	33.2"
MOUNTING PIN DIAMETER	1-1/8"
PACKAGING DIMENSIONS	36"L x 25"W x 9.5"H
WEIGHT	124 lb

7500D-H

Open Frame Gas Generator

The 7500D-H open frame generator keeps you powered when it matters most. Perfect for outages, remote job sites, or outdoor events, it delivers dependable 120V/240V power for homes or businesses.

Built with an open frame for easy access, it is simple to maintain and ready to start every time with electric and recoil options. Rugged and built to last, the 7500D-H gives you reliable power wherever you need it.



- 1 Durable powdercoated steel roll cage
- 2 Gas Tank
- 3 Electric Start
- 4 Easy Access to Outlets
- 5 Rugged & Reliable Engine
- 6 420 cc displacement
- 7 Flat free tires
- 8 Stabilizing rubber feet
- 9 Folding handles



DETAILS

ENGINE TYPE	HWASDAN H420
GAS MAX WATTS / RUNNING WATTS	7000 / 6500
GAS CONSUMPTION RATE AT MAX OUTPUT	4.48 L / hr
VOLTS	120V / 240V
ENGINE START	Recoil + Electric
FUEL CAPACITY	Gas / 25 L
OIL CAPACITY	1.1 L
PACKAGING DIMENSIONS	29" x 21" x 24"
WEIGHT	200 lb





2250IS

Silent GAS Inverter Generator

The 2250IS silent inverter generator delivers clean, quiet power wherever you go. Compact and ultra-portable, it is ideal for camping, RV trips, tailgating, or emergency backup.

With under 2% voltage distortion, it is safe for sensitive electronics, while economy mode saves fuel by matching engine speed to your power needs. Reliable, efficient, and whisper-quiet, the 2250IS keeps your essentials running without the noise.



- 1 Sound dampening shell
- 2 Comfortable carry handle
- 3 79.9 cc displacement
- 4 Easy access to outlets
- 5 Parallel ready
- 6 Stabilizing rubber feet
- 7 H.D. tires for easy transport

DETAILS

ENGINE TYPE	HWASDAN H80i
GAS MAX WATTS / RUNNING WATTS	1800W / 2000W
GAS CONSUMPTION RATE AT MAX OUTPUT	1.72 L / hr
VOLTS	120V
ENGINE START	Recoil
FUEL CAPACITY	4L
OIL CAPACITY	0.4 L
PACKAGING DIMENSIONS	21"x13"x22"
WEIGHT	45 lb

4500IE

Silent GAS Inverter Generator

The 4500IE silent inverter generator delivers clean, quiet power for any setting. Ideal for homes, campgrounds, and events, it provides stable electricity with less than 2% distortion, safe for sensitive electronics.

Economy mode boosts fuel efficiency, while built-in safeguards like overload protection and low oil shutdown ensure dependable, worry-free operation. Powerful, efficient, and whisper-quiet, the 4500IE is ready wherever you need reliable power.



- 1 Comfortable carry handle
- 2 Sound dampening shell
- 3 223 cc displacement
- 4 Parallel ready
- 5 Easy access to outlets
- 6 Stabilizing rubber feet
- 7 H.D. tires for easy transport

DETAILS

ENGINE TYPE	HWASDAN H225i
GAS MAX WATTS / RUNNING WATTS	3500W / 4000W
GAS CONSUMPTION RATE AT MAX OUTPUT	2.5L/hr
VOLTS	120V
ENGINE START	Recoil
FUEL CAPACITY	12L
OIL CAPACITY	0.6 L
PACKAGING DIMENSIONS	25"x19"x23"
WEIGHT	89 lb





50WB26/80WB26

Portable Semi-Trash Pump

Tackle tough water transfer jobs with confidence using the 50WB26 and 80WB26 semi-trash pumps. Designed for debris-filled water, these gas-powered, self-priming pumps deliver dependable performance anywhere, on construction sites, farms, or during emergency flood response.

Built tough with corrosion-resistant components and EPA-certified engines, they handle dirty water with ease while staying portable and easy to set up. Compact, durable, and ready for real-world conditions, the 50WB26 and 80WB26 keep your operation moving when it matters most.



- 1 Outlet
- 2 Inlet
- 3 Aluminium housing
- 4 Powder-coated steel frame
- 5 212 cc displacement



KIT INCLUDES

- 1 Spare Plug Wrench
- 2 Connectors
- 1 Adapter

DETAILS: MODEL 50WB26

ENGINE TYPE	HWASDAN H210
RATED POWER	4300 W/3600 RPM
GPM/PSI	132/37
SUCTION/LIFT	23'/85'
FUEL CAPACITY	3.6 L
OIL CAPACITY	0.6 L
INLET/OUTLET	2"
START	Recoil
PACKAGING DIMENSIONS	20"x18"x18"
WEIGHT	71 lb

DETAILS: MODEL 80WB26

ENGINE TYPE	HWASDAN H210
RATED POWER	4300 W/3600 RPM
GPM/PSI	290/37
SUCTION/LIFT	23'/85'
FUEL CAPACITY	3.6 L
OIL CAPACITY	0.6 L
INLET/OUTLET	3"
START	Recoil
PACKAGING DIMENSIONS	21"x19"x19"
WEIGHT	75 lb

REPLACEMENT ITEMS

50WB26-1	2" Tube adapter
50WB26-2	Plastic filter net
2INCLAMP	2" Clamp for outlet + house
2INGASKET	2" Rubber gasket
80WB26-1	3" tube adapter
80WB26-2	Steel filter kit for suction hose
3INCLAMP	3" clamp for outlet + house
3INGASKET	3" rubber gasket





50ZB28/80ZB28

Portable Water Pump

The 50ZB28 and 80ZB28 gas-powered water pumps are built for fast, efficient water transfer in any location. Ideal for flood control, irrigation, construction dewatering, motocross track prep, and dust suppression, they deliver strong, dependable performance wherever water needs to move.

Both models feature self-priming designs for quick startup and durable, corrosion-resistant construction that handles small debris with ease. Lightweight and easy to transport, they provide powerful flow without relying on electricity, making them perfect for remote areas or emergency situations.

DETAILS: MODEL 50ZB28

ENGINE TYPE	HWASDAN H200
RATED POWER	3800 W/3600 RPM
GPM/PSI	132/40
SUCTION/LIFT	26'/92'
FUEL CAPACITY	3.6 L
OIL CAPACITY	0.6 L
INLET/OUTLET	2"
START	Recoil
PACKAGING DIMENSIONS	20"x17"x18"
WEIGHT	51 lb

DETAILS: MODEL 80ZB28

ENGINE TYPE	HWASDAN H200
RATED POWER	3800 W/3600 RPM
GPM/PSI	264/40
SUCTION/LIFT	26'/92'
FUEL CAPACITY	3.6 L
OIL CAPACITY	0.6 L
INLET/OUTLET	3"
START	Recoil
PACKAGING DIMENSIONS	20"x17"x18"
WEIGHT	56 lb

REPLACEMENT ITEMS

50ZB28-1	Tube Adapter
50ZB28-2	Plastic Filter Kit For Suction Hose
50ZB28-3	Intake+Check Valve
50ZB28-4	Water Outlet Sealing Gasket
2INCLAMP	2" Clamp For Suction Hose
2INGASKET	Rubber Gasket. 2" Adapter
80ZB28-1	3" Tube Adapter For Parts
80ZB28-2	Plastic Filter Kit For Suction Hose
80ZB28-3	Intake+Check Valve
80ZB28-4	Water Outlet Sealing Gasket
3INCLAMP	3" Clamp For Suction Hose
3INGASKET	Rubber Gasket. 3" Adapter

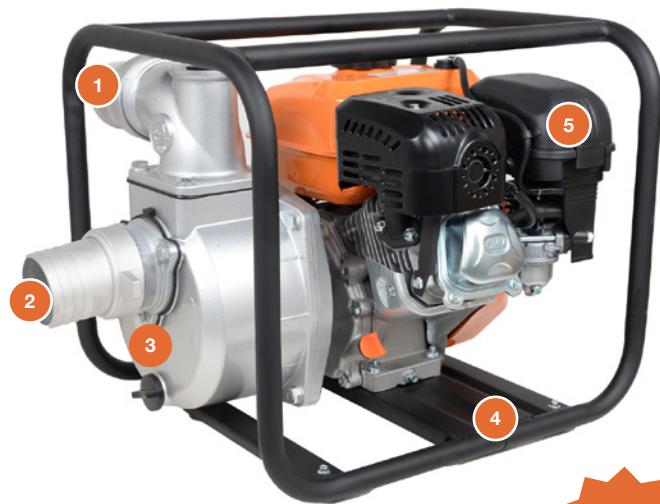

- 1 Outlet
- 2 Inlet
- 3 Aluminium housing
- 4 Powder-coated steel frame
- 5 196 cc displacement

KIT INCLUDES

- 1 Spare Plug Wrench
- 2 Connectors
- 1 Adapter





EFP210

Emergency Fire Pump Kit

This fire pump kit delivers fast, reliable firefighting power in remote areas. Pumping up to 7,920 gallons per hour with a 170-foot discharge height, it draws water from ponds, pools, or other nearby sources to help contain fires and protect property. The 212cc 4-cycle engine starts quickly, and low oil shutdown adds extra protection. Compact and portable, it is ideal for farms, acreages, and remote Canadian locations.



- 1 2" Diameter 12' Suction hose
- 2 Built-in data plate
- 3 Portable tilt back frame
- 4 212 cc displacement
- 5 1.5" Diameter 50' fire hose
- 6 Outlet
- 7 Inlet
- 8 Aluminium housing
- 9 Powder-coated steel frame
- 10 Oversized wheels for rugged terrain

KIT INCLUDES

- Fire Hose EFP210-8
- Suction Hose EFP210-7
- Fire Hose Nozzle EFP210-1

DETAILS

ENGINE TYPE	HWASDAN H210
RATED POWER	4300 W/3600 RPM
GPM/PSI	132/90
SUCTION/LIFT	24'/170'
INLET/OUTLET	2"
START	Recoil
PACKAGING DIMENSIONS	30"x30"x23"
WEIGHT	125 lbs

REPLACEMENT ITEMS

EFP210-1	Fire Nozzle
EFP210-2	Foot Valve
EFP210-3	Fire Nozzle Adapter
EFP210-4	Reducing Adapter
EFP210-5	Type A Camlock for Suction Port
EFP210-6	Type C Camlock for Suction Hose
EFP210-7	Suction Hose - 2" x 12'
EFP210-8	Fire Hose - 1.5" x 50'
EFP210-9	Sealing Gasket
EFP210-10	Whorl Plug
EFP210-11	Pump Housing Assembly





HD-01

Hydraulic Post Digger

A tow-behind gas-driven hydraulic post hole digger is a valuable tool for digging holes quickly and easily, reducing manual labor and time. It is highly efficient in digging deep and consistent holes for fence posts, signposts, and other applications.

With its adjustable auger diameter, depth, and speed settings, it can accommodate a variety of post sizes and soil types. It is portable and easy to operate, making it perfect for use in remote or hard-to-reach locations.



- 1 2" towing coupler
- 2 Low oil alert sensor
- 3 Includes 5 sizes of auger bits: 5", 6", 8", 10" and 12"

DETAILS

ENGINE	9HP Loncin G270F
FUEL CAPACITY	6L
HYDRAULIC FLUID CAPACITY	4 Gallons
PRESSURE RELIEF SETTING	2000PSI
MOTOR SPEED	55RPM
MOTOR TORQUE	3800in.-lbs
MAXIMUM DIAMETER	30cm
MAXIMUM DEPTH	213cm
MAXIMUM TOW SPEED	45MPH
TIRES	16"
PACKAGING DIMENSIONS	82"L x 37"W x 28"H
WEIGHT	560 lb

REPLACEMENT ITEMS

HD01-1	5" Replacement Auger for Post Hole Digger
HD01-2	6" Replacement Auger for Post Hole Digger
HD01-3	8" Replacement Auger for Post Hole Digger
HD01-4	10" Replacement Auger for Post Hole Digger
HD01-5	12" Replacement Auger for Post Hole Digger

SC65

Sickle Mower

A walk-behind sickle mower is best for cutting long grass, weeds, and brush in tight or difficult to reach spaces where larger mowers can't fit. It is easy to operate, highly maneuverable, and can tackle rough terrain with ease.

Additionally, walk-behind sickle mowers are highly efficient and can cut through thick vegetation quickly, making them an excellent tool for maintaining overgrown areas.



- 1 Single direction reciprocating cutting mode. No reverse cutting
- 2 Gasoline engine with recoil start
- 3 OHV 4 stroke horizontal shaft
- 4 1.0-1 gear shifting
- 5 212 cc displacement
- 6 Cut materials fall flat behind the mower
- 7 Tires are 6"-13 x 5.00 - 6
- 8 Produces very little debris compared to other mowers
- 9 Provides a clean cut

DETAILS

ENGINE	Ducar DH-212 6.5HP
FUEL CAPACITY	3.6L
OIL CAPACITY	0.6L
SPEED	30m/min.
CUTTING DIMENSIONS	80cm W x 1-8cm H x 2.5cm diameter
START	Recoil
PACKAGING DIMENSIONS	48"L x 21"W x 25"H
WEIGHT	195 lbs

REPLACEMENT ITEMS

SC65-1	Replacement blade assembly
SC65-2	Shaft sleeve replacement for scythe mower





Outdoor Equipment & Tools

General Equipment



Outdoor Equipment & Tools

SG-01

Stump Grinder

A walk behind gas driven stump grinder is an efficient tool for removing tree stumps. It is portable and maneuverable, allowing access to tight spaces where larger machines cannot reach.

The grinder reduces stumps to chips, saving time and energy compared to manual removal methods. It also prevents the regrowth of the tree, improves landscaping, and eliminates tripping hazards.



- 1 9 hardened tungsten carbide teeth
- 2 4 stroke engine
- 3 Ergonomic, adjustable operator handle for effortless operation
- 4 Lightweight design minimizes operator fatigue
- 5 Heavy duty tires measuring 6" -145 / 70 -6
- 6 Drum Bracket

DETAILS

ENGINE	Jiangdong JF420
FUEL CAPACITY	7L
OIL CAPACITY	1.1 L
CUTTER DEPTH	9.3" above ground, 23.6" below ground
HP/RPM	15/3600
CUTTING WHEEL DIMENSIONS	12"x3.5"
PACKAGING DIMENSIONS	42"L x 32"W x 22"H
WEIGHT	283 lb

REPLACEMENT ITEMS

SG01-1	Replacement straight blade
SG01-2	Replacement left blade
SG01-3	Replacement right blade
SG01-4	Clutch for stump grinder
SG01-5	Replacement belt
SG01-6	Replacement brake connector
SG01-7	Replacement throttle cable

GP6

Garlic Planter

The Garlic Planter is a reliable, mechanical device designed specifically for small and medium-sized farms. With this garlic farming machine, the planting process becomes fast and efficient. Mechanical garlic planting not only saves time but also ensures precise placement of bulbs in the soil.



- 1 3 point attachment that can be used with a variety of farm and chore equipment
- 2 Rigid and durable iron front barrel
- 3 Machine is driven by two gear boxes

KIT INCLUDES

- Disc-trencher mode for sandy and mixed ground (installed)
- Plough trencher for dry ground
- Extended stool area

DETAILS

ROWS	6
LINE SPACING	8"
DEPTH ADJUSTMENT	2"
PACKAGING DIMENSIONS	55"L x 55"W x 37.5"H
WEIGHT	640 lb





Garlic Roots Cutter

The Garlic Roots Cutter is a professional-grade solution designed for garlic farmers and processors who need efficient, consistent root trimming. Its dual-sided cutting system allows both blades to operate simultaneously, creating a smooth, continuous workflow that speeds up processing.

Constructed with durable, lightweight plastic housing and high-quality stainless-steel components, the machine is built for long-term use. It is corrosion- and wear-resistant, easy to clean, and simple to position on workbenches or processing tables.

Powered for reliable performance, the cutter delivers clean, precise cuts that preserve garlic bulb quality while removing roots quickly and efficiently. A simple one-button operation ensures ease of use for any operator.

Ideal for small to medium-scale operations, this compact yet sturdy machine significantly reduces labor time compared to manual trimming. Its ergonomic design and manageable weight make it a practical, user-friendly solution for high-volume garlic processing.



- 1 Elongated cutting width ensures precise cutting
- 2 Two sides dual cutting function to increase the amount of garlic you can cut at one time
- 3 Easily connects to 48V battery

GRC48

Garlic Roots Cutter

DETAILS	
POWER SUPPLY	48V DC
BATTERY VOLTAGE	48V (not included)
CUTTING AREA	3.6"
IDEAL MIN. CLOVE DIA.	2"
PACKAGING DIMENSIONS	16"L x 10.5"W x 8.5"H
WEIGHT	12.5 lb

REPLACEMENT ITEMS	
GRC48-1	Replacement Blade Set (1 left & 1 right)

BATTERY OPTIONS	
•	4 x 12V batteries (series connection)
•	2 x 24V batteries (series connection)
•	Batteries not included



GRC110

Garlic Roots Cutter

This piece of equipment is similar to the GRC48 however, it has been adapted to a conversion power supply unit that will convert 110V AC to 48V DC for the motor of the machine to work. The converter has been attached to the side of the machine for ease of use.

DETAILS	
LENGTH	16"
WIDTH	12"
HEIGHT	8.5"
WEIGHT	12.5 lb
POWER SUPPLY	Conversion power supply – 110V AC to 48V DC





GSS110

Garlic Splitter and Sorter

The Garlic splitting and sorting machine automates the splitting process, which would otherwise be time-consuming and labor-intensive if done manually. The splitter and sorter machine ensures that each garlic bulb is evenly split, reducing damage to the cloves and preserving their quality for planting or further processing.

Equipped with adjustable settings, the splitter and sorter machine allowing operators to handle different garlic sizes and varieties with ease offering versatility and adaptability. The machine significantly increases productivity, as it can process large quantities of garlic in a fraction of the time compared to manual methods.

The robust construction ensures durability, allowing it to withstand heavy use in commercial farming operations. It enhances efficiency, minimizes labor costs, and ensures a more consistent quality of split garlic, which is vital for both planting and food processing purposes.



- 1 Adjustable splitter for different garlic bulb sizes
- 2 2 transformers for continual use of both functions at the same time
- 3 Locking caster wheels for easy maneuverability
- 4 Dual function of sorting and splitting for increased efficiency

DETAILS

VOLTAGE	110V
BULBS PER HOUR	800-1000kg
PACKAGING DIMENSIONS	58"L x 40"W x 31"H
WEIGHT	232 lb





ZB-G100A/ZB-G60A

Propane Forced-Air Heater

These Propane Forced Air Heaters are robust, light weight and compact in design with strong and long lasting construction. The compact design makes them easy for handling, transportation and maintenance. The heaters include a pressure regulator and 3m Hose Flame failure. Overheat auto shut off protection safety gas valve with thermocouple is also included. Another safety feature is the motor is thermally protected and includes an electrovalve. The heaters have high efficiency combustion with no fumes and are odourless.



DETAILS: MODEL ZB-G100A

OUTLET TEMPERATURE	660°C
PRESSURE OUTPUT	11" W.C.
BTU	70,000-100,000
HEATING AREA	410-586 m ³
FUEL CONSUMPTION	3.22-4.58 L / hr
PACKAGING DIMENSIONS	28" L x 11.2" W x 18.5" H
WEIGHT	45 lb

DETAILS: MODEL ZB-G60A

OUTLET TEMPERATURE	660°C
PRESSURE OUTPUT	11" W.C.
BTU	40,000-60,000
HEATING AREA	234-352 m ³
FUEL CONSUMPTION	1.83-2.76 L / hr
PACKAGING DIMENSIONS	28" L x 38.5" W x 22" H
WEIGHT	70 lb

REPLACEMENT ITEMS

G100-040000	Plastic Black Cover for ZB-G100A (#17)
G100-010000	Handle for ZB-G60A & ZB-G100A (#15)
G100-090000	Fan Switch for ZB-G60A & ZB-G100A (#32)
G100A-050000UL	Motor Assembly for ZB-G100A (#25)
G100A-120000UL	Valve Body Assembly for ZB-G100A (#33)
G100A-150000UL	Ignition Needle for ZB-G100A (#26)
G100A-210000	Copper Tube Assembly for ZB-G100A (#4)
G40-040000	Plastic Black Voer for ZB-G60A (#17)
G40-070000	Fan Bracket for ZB-G60A & ZB-G100A (#18)
G40-130000	Plastic Knobs for ZB-G60A & ZB-G100A (#16)
G40A-050000UL	Motor Assembly for ZB-G60A (#25)
G40A-120000UL	Valve Body Assembly for ZB-G60A (#33)
G40A-140000	Thermocouple Assembly for ZB-G60A & ZB-G100A (#23)
G40A-150000	Ignition Needle for ZB-G60A (#26)
G40A-170000	PC Board for ZB-G60A & ZB-G100A (#22)
G40A-210000	Copper Tube Assembly for ZB-G60A (#4)
G60-250000UL	Regulator & Hose Assembly for ZB-G100A & ZB-G60A (#21)



- 1 100% heat efficiency
- 2 Ergonomic handle for easy maneuverability
- 3 Continuous spark ignition

KIT INCLUDES

- 1.6 m power cord
- Set of pressure regulators and 3 m hose
- Thermostat control

REQUIRES

- 110V / 60HZ power supply
- Propane fuel





Outdoor Equipment & Tools

Heaters



Outdoor Equipment & Tools

ZB-K70/ZB-K125

Kerosene Air Heaters

These kerosene forced air heaters are robust, light weight and compact in design with strong and long lasting construction. The compact design makes them easy for handling, transportation and maintenance. The heaters include a pressure regulator and 3m hose flame failure. Flame failure and overheat auto shut off protection. Another safety feature is the motor is thermally protected and includes an electronic flame control with photocell. The heaters have high efficiency combustion with no fumes and are odourless.



- 1 100% heat efficiency
- 2 Stainless steel combustion chamber
- 3 Tires on ZB-K125 measure 8" with 1/2" axle bore hole
- 4 Continuous spark ignition

KIT INCLUDES

- 1.6 m power cord
- Set of pressure regulators and 3 m hose
- Thermostat control
- Oil tank and level indicator
- Oil tank filter
- Suction filter

REQUIRES

- 110V / 60HZ power supply
- Kerosene fuel

DETAILS: MODEL ZB-K70

OUTLET TEMPERATURE	640°C
BTU	70,000
HEATING AREA	400 m ³
FUEL CONSUMPTION	2.01 L / hr
FUEL TANK SIZE	19 L
PACKAGING DIMENSIONS	32" L x 11.5" W x 16" H
WEIGHT	31 lb

DETAILS: MODEL ZB-K125

OUTLET TEMPERATURE	660°C
BTU	125,000
HEATING AREA	740 m ³
FUEL CONSUMPTION	3.6 L / hr
FUEL TANK SIZE	38 L
PACKAGING DIMENSIONS	41.5" L x 21.3" W x 25" H
WEIGHT	58 lb

REPLACEMENT ITEMS

K125-070100	Nozzle For ZB-K125 (#26)
K125-120001	Motor For ZB-K125 (#50)
K125-120200	Pump Body For ZB-K125 (#22)
K125-120400	Rotor Kit For ZB-K125 (#23)
K125-120500	Blade For ZB-K125 (#24)
K125-121500	Air Pressure Gauge For ZB-125K (#51)
K125-130000	Fan Guard For ZB-K125 (#36)
K125-200102	PCB For ZB-K125 (#55)
K215-121200	Ball For ZB-K70 & ZB-K125 (#10)
K45-070300	Ignitor For ZB-K70 & ZB-K125 (#54)
K45-120100	Motor For ZB-K70 (#50)
K45-120200	Pump Body For ZB-K70 (#22)
K45-120400	Rotor Kit For ZB-K70 (#23)
K45-120500	Blade For ZB-K70 (#24)
K45-120600	End Pump Cover For ZV-K70 & ZB-K125 (#25)
K45-120700	Output Filter For ZB-K70 & ZB-K125 (#30)
K45-120900	Lint Filter For ZB-K70 & ZB-K125 (#32)
K45-121000	Filter Kit For ZB-K70 & ZB-K125 (#33)
K45-121100	End Cover Filter For ZB-K70 & ZB-K125 (#34)
K45-121300	Spring For ZB-K75 & ZB-K125 (#11)
K45-121400	Adjustment Screw For ZB-K70 & ZB-K125 (#35)
K45-130000	Fan Guard For ZB-K70 (#36)
K45-240000	Photo Cell For ZB-K70 & ZB-K125 (#58)
K45-250202	Overheat Protector For ZB-K70 (#24)
K70-070100	Nozzle For ZB-K70 (#26)
K70-200102	PCB For ZB-K70 (#55)





PSH10241/PSH15203/PSH15241

Portable Electric Salamander Heaters

These portable electric heaters are ideal for workshops, garages or construction sites. They feature a rugged powder coated steel construction and safety features like a safety thermal cutout, auto reset overheat protection and a tip-over switch. The finned tubular heating elements are designed for efficiency and long life. The 10" wheels and handle make this heater very easy to move around and position. Safety guards on both the intake and output ends.

DETAILS: MODEL PSH10241

KILOWATTS	10 KW
AMPS	41.7
VOLTS	240 V
BTU	34,120
TEMPERATURE RISE	46°F
COVERAGE AREA	1,500 ft ³ / min
PHASES	1
PACKAGING DIMENSIONS	28" L x 38.5" W x 22" H
WEIGHT	73 lb

DETAILS: MODEL PSH15203

KILOWATTS	15 KW
AMPS	41.7
VOLTS	208 V
BTU	51,180
TEMPERATURE RISE	61°F
COVERAGE AREA	1,500 ft ³ / min
PHASES	3
PACKAGING DIMENSIONS	28" L x 38.5" W x 22" H
WEIGHT	70 lb

DETAILS: MODEL PSH15241

KILOWATTS	15 KW
AMPS	62.5
VOLTS	240 V
BTU	51,180
TEMPERATURE RISE	46°F
COVERAGE AREA	1,500 ft ³ / min
PHASES	1
PACKAGING DIMENSIONS	28" L x 38.5" W x 22" H
WEIGHT	70 lb



- 1 10" wheels
- 2 Rugged powder coated steel construction
- 3 Durable handle allows for easy moving
- 4 Finned tubular heating element designed for efficiency and long life

NOT INCLUDED

- Power cord
- Plug





Outdoor Equipment & Tools

Pressure Washers



Outdoor Equipment & Tools

GPW2300 / GPW2900 / GPW3100

High Performance Pressure Washer



Take on any cleaning challenge with our powerful line of pressure washers. Whether you are washing vehicles, cleaning construction equipment, or removing tough grime and stains from driveways and shop floors, our units deliver power and performance. Perfect for contractors, maintenance crews, and serious DIY-ers who need dependable cleaning performance day after day.



GPW2300



GPW2900



GPW3100

- 1 25' Steel Braided Rubber Hose
- 2 Durable handle allows for easy moving
- 3 34" Metal Lance Gun
- 4 2" 11" Plastic Tire
- 5 Pump Cover

KIT INCLUDES

- 4 types of quick connect nozzles: 0°, 25°, 40° and detergent
- Built-in detergent injection
- 3L detergent bottle

DETAILS

ENGINE	5.5HP Vertical
GPM/PSI	2.0/3000
PUMP TYPE	Axial Aluminum
OIL CAPACITY	0.55 L
FUEL CAPACITY	1 L
HOSE DIAMETER	1/2'
START	Recoil Start
PACKAGING DIMENSIONS	22"L x 16"W x 25"H
WEIGHT	60 lb

- 1 50' Steel Braided Rubber Hose
- 2 Durable handle allows for easy moving
- 3 34" Metal Lance Gun
- 4 2" 10" Solid Rubber Tire
- 5 Oil Fill Cap

KIT INCLUDES

- 4 types of quick connect nozzles: 0°, 25°, 40° and detergent
- Built-in detergent injection
- 3L detergent bottle

DETAILS

ENGINE	6.5HP Horizontal
GPM/PSI	2.6/3500
PUMP TYPE	Brass Axial
OIL CAPACITY	0.6 L
FUEL CAPACITY	3.6 L
HOSE DIAMETER	1/2'
START	Recoil Start
PACKAGING DIMENSIONS	24"L x 17"W x 23"H
WEIGHT	82 lb

- 1 50' Steel Braided Rubber Hose
- 2 Durable handle allows for easy moving
- 3 34" Metal Lance Gun
- 4 2" 13" Pneumatic Tire

KIT INCLUDES

- 5 types of quick connect nozzles: 0°, 15°, 25°, 40° and detergent
- Built-in detergent injection
- 3L detergent bottle

DETAILS

ENGINE	6.5HP Horizontal
GPM/PSI	2.5/3500
PUMP TYPE	Brass Triplex
OIL CAPACITY	0.6 L
FUEL CAPACITY	3.6 L
HOSE DIAMETER	1/2'
START	Recoil Start
PACKAGING DIMENSIONS	27"L x 17"W x 25"H
WEIGHT	84 lb

